

HIGH SPEED HOISTS

STANDARD FEATURES

- ▷ Lightweight aluminium housing
- ▷ Toku rotary vane motor
- ▷ Robust epicyclic gearbox
- ▷ Failsafe automatic internal disc brake
- ▷ Mechanical upper & lower switches
- ▷ Aluminium housing
- ▷ Internal silencing down to 80 dB(A)
- ▷ Alloy safety swivel hooks with safety catch
- ▷ Load chain 6.3 x 19mm of European manufacture to EN818-7

AVAILABLE OPTIONS

- ▷ Marine specification
- ▷ Special paint systems
- ▷ Corrosion protection
- ▷ ATEX specification
- ▷ Chain collectors (PVC, galvanised or stainless steel)
- ▷ Air Service units
- ▷ Festoon systems
- ▷ Radio control
- ▷ Main air shut off valve

MODEL	WLL	LIFTING SPEED WITH LOAD	LIFTING SPEED WITHOUT LOAD	LOWERING SPEED WITH LOAD
TCS-980	980 kg	8.5 m/min	17.0 m/min	17 m/min
	AIR CONSUMPTION LIFTING	AIR CONSUMPTION LOWERING	AIR CONNECTION	MINIMUM HOSE DIA.
TCS-980	28 l/sec	33 l/sec	1/2" BSP	1/2" HOSE
	CHAIN FALLS	WORKING PRESSURE	WEIGHT WITH 3M HOL	WEIGHT PER ADDITIONAL METRE HOL
TCS-980	2	6 bar	23.5 kg	1.6 kg

C = CORD CONTROL DP = PENDANT

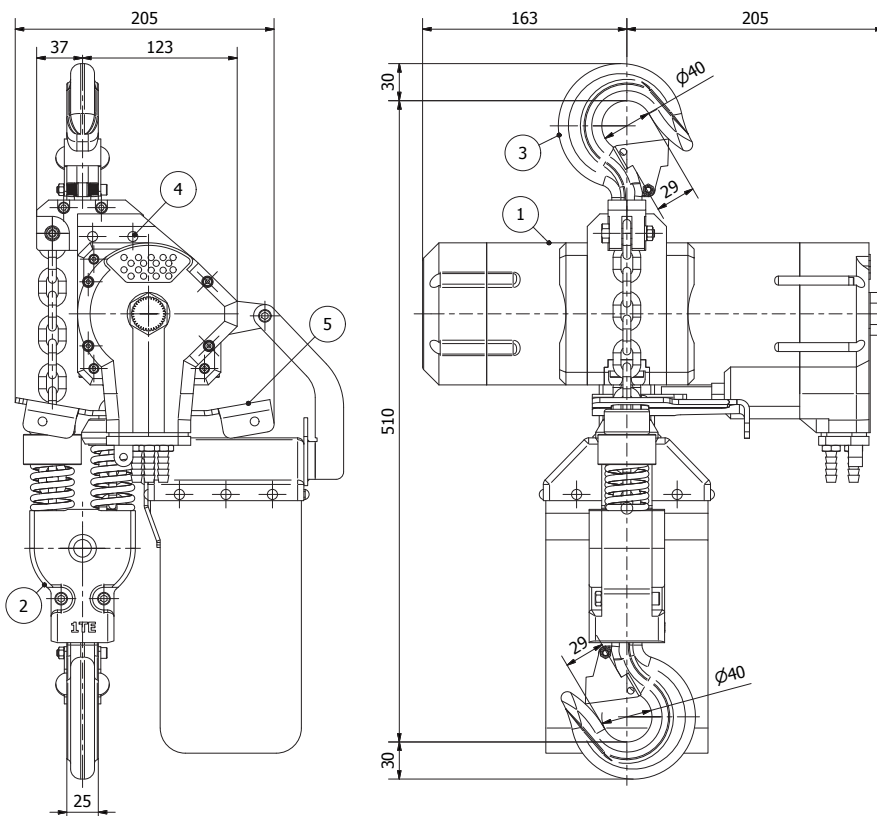

All measurements are in mm
Information subject to change without notice

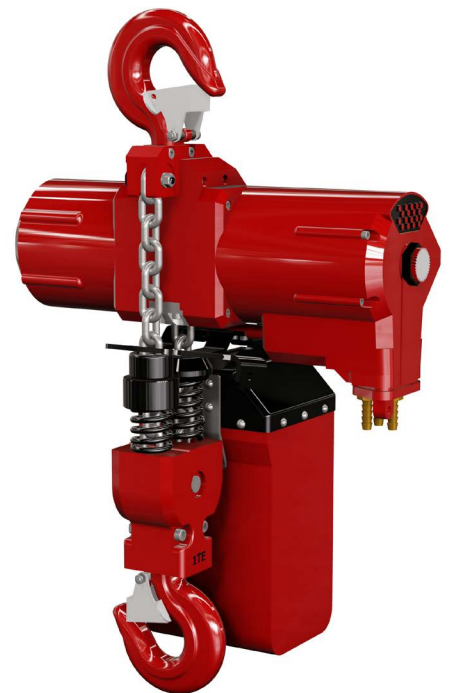

Image for illustration purposes only

TCS-980